

HUBA

Type 528 Pressure Transmitter, Relative/Gage & Absolute

F.S Pressure Ranges from Vac. to 750 PSI, Voltage/Current/Ratiometric Outputs

DESCRIPTION

Huba Type 528 pressure transmitters have a compact design along with a high measurement accuracy.

The transmitters utilize proven Huba ceramic technology in use on Huba pressure measurement products for over 20 years.

Wetted materials include 316 SS connections, ceramic sensor and a selection of seal materials including FPM, EPDM and NBR. These transmitters are suitable for applications across a broad spectrum of industries.

FEATURES

- Compact, rugged construction
- Negligible temperature influence on accuracy
- Large selection of connections available
- Quick customer cable mounting with swift connector

MAIN APPLICATIONS

- Industrial Automation
- HVAC Systems
- Water Treatment Plants
- Hydraulic and Pneumatic Systems
- Process Industries (Chemical, Food, Pharmaceutical)
- Environmental Monitoring
- Energy Sector (Oil, Gas, Renewable Energy)
- Marine and Offshore



SPECIFICATIONS

Pressure range			
Relative	-1 ... 0 – 60 bar		
Absolute	0 ... 1 – 16 bar		
Operating conditions			
Medium			Liquids and gases
Temperature	Medium	FPM	-15 ... +125 °C (Ex) -15 ... +120 °C
		EPDM	-40 ... +125 °C (Ex) -30 ... +120 °C
		NBR	-20 ... +100 °C
		MVQ	-40 ... +125 °C (Ex) -30 ... +120 °C
	FPM	-40 ... +125 °C (Ex) -30 ... +120 °C	
	Ambient		-30 ... +85 °C (Ex) -25 ... +85 °C
	Storage		-50 ... +100 °C
Tolerable overload /		≤ 4 bar	3.0 x fs
Rupture pressure		> 4 bar	2.5 x fs
Materials			
Cover		Stainless steel 1.4404 / AISI 316L	
Plug accommodation		Polyarylamide 50% GF UL 94 V-0	
Materials in contact with medium	Pressure connection	Stainless steel 1.4404 / AISI 316L	
		PVDF	
	Sensor	Ceramic Al ₂ O ₃ (96%)	
	Sealing material	FPM, EPDM, NBR, MVQ	

Electrical overview				
	Output	Power supply	Load	Current consumption
2 wire	4 ... 20 mA	7 ... 33 VDC	< supply voltage · 7 V/0.02 A [Ohm]	< 23 mA
	(Ex) 4 ... 20 mA	10 ... 30 VDC	< supply voltage · 10 V/0.02 A [Ohm]	< 23 mA
3 wire	0 ... 5 V	7 ... 33 VDC	>10 kOhm / < 100 nF	< 7 mA
	1 ... 6 V	8 ... 33 VDC	>10 kOhm / < 100 nF	< 7 mA
	0 ... 10 V	12 ... 33 VDC	>10 kOhm / < 100 nF	< 7 mA
	0 ... 10 V	12 ... 33 VDC / 24 VAC ±15%	>10 kOhm / < 100 nF	< 7 mA
	ratiom. 10 ... 90%	5 VDC ± 10%	>10 >10 kOhm / < 100 nF	< 7 mA
	(Ex) ratiom. 10 ... 90%	5 VDC ± 10%	>10 kOhm / < 100 nF	< 7 mA
Polarity reversal protection		Short circuit proof and protected against polarity reversal. Each connection is protected against crossover up to max. supply voltage.		
Insulation voltage		500 VDC		

SPECIFICATIONS

Dynamic response		
Response time	< 2 ms, 1 ms typ	
Load cycle	< 100 Hz	
Electrical connection	Protection standard	Protection class
Swift connector with or without cable 1.5 / 2.0 / 3.0 / 5.0 m (PVC spec.)	IP 67	III
Connector DIN EN 175301-803-A or C (industrial standard 9.4 mm)	IP 65	III
Metri Pack 150 P2S Series	IP 67	III
Connector M12x1	IP 67	III
Braids	IP 65	III
Connector RAST 2.5 (3 wire, only)	IP 00	III

Pressure connection		
Inside thread	$\frac{7}{16}$ - 20 UNF	
	$\frac{1}{2}$ - 14 NPT	
	G $\frac{3}{4}$	with O-Ring seal FPM (-30 ... +135 °C)
Outside thread	$\frac{7}{16}$ - 20 UNF	sealing cone
	$\frac{1}{4}$ - 18 NPT	
	$\frac{7}{16}$ - 20 UNF	sealed at back SAE 4 with O-Ring seal FPM (-20 ... +135 °C)
	G $\frac{3}{4}$, G $\frac{1}{2}$, G $\frac{3}{8}$	sealed at back DIN 3852-E with Profile seal ring in FPM (-30 ... +135 °C)
	G $\frac{3}{4}$, G $\frac{1}{2}$	sealed at back and manometer (combi) with Profile seal ring in FPM (-30 ... +135 °C)
	R $\frac{3}{4}$	EN 10226
	$\frac{1}{8}$ - 27 NPT	
	G $\frac{3}{8}$	sealed at front or sealed at back and manometer (combi) with Profile seal ring in FPM (-30 ... +135 °C)
	M10x1	sealed at back DIN 3852-E with Profile seal ring in FPM (-30 ... +135 °C)
	M20x1.5	sealed at front and manometer (combi)
G $\frac{3}{4}$, G $\frac{1}{2}$	sealed at front	

Installation arrangement	
Unrestricted	Recommendation: Pressure connection facing downwards

Tests / Admissions	
Electromagnetic compatibility	CE conformity acc. EN 61326-2-3
Enhanced EMC protection	EN 50121-3-2
Shock acc. IEC 68-2-27	100 g, 11 ms half sine wave, all 6 directions, free fall from 1 m on concrete (6x)
Constant shock acc. IEC 68-2-29	40 g for 6 ms, 1000x all 3 directions
Vibration acc. IEC 68-2-6	20 g, 15 ... 2000 Hz, 15 ... 25 Hz with amplitude \pm 15 mm, 1 Octave/min. all 3 directions, 50 constant load
UL	ANSI/UL 61010-1 acc. E325110
Drinking water approval	NSF/ANSI 61/372 acc. MH60087
EAC	

Protection against explosion Ex	ratiom. 10 ... 90%	4 ... 20 mA
Intrinsic safety <<i>>	Ex II 1/2 G Ex ia IIC T4 Ga/Gb	Ex II 1/2 G Ex ia IIC T4 Ga/Gb
	Ex II 1/2 D Ex ia IIIC T125ÅC Da/Db	Ex II 1/2 D Ex ia IIIC T125ÅC Da/Db
EC type examination certificate	SEV 15 ATEX 0173	SEV 10 ATEX 0145
Connection to certified intrinsically safe resistive circuits with maximum values	Ui \leq 15 VDC; Ii \leq 200 mA; Pi \leq 750 mW	Ui \leq 30 VDC; Ii \leq 100 mA; Pi \leq 750 mW
Effective internal inductance and capacitance for versions with plugs complying with EN 175301-803-A or M12x1	Li = 0 nH; Ci \leq 150 nF	Li = 0 nH; Ci = 0 nF
IECEX		SEV 16.0007

Weight	~ 90 g
--------	--------

Packaging (Please state on order)	
Single packaging in cardboard	accessories integrated
Multiple packaging in cardboard (25 pcs)	

ELECTRICAL CONNECTIONS **

2 wire

Connector DIN
EN 175301-803-A or C

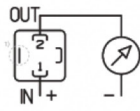

1 (IN) 2 (OUT)

Swift connector

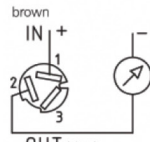

1 (IN) 2 (OUT)

Connector M12x1

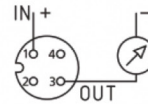

1 (IN) 3 (OUT)

Connector M12x1

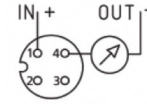

1 (IN) 4 (OUT)

3 wire

Connector DIN
EN 175301-803-A or C

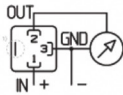

1 (IN) 2 (OUT) 3 (GND)

Swift connector

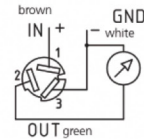

1 (IN) 2 (OUT) 3 (GND)

Connector M12x1

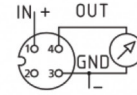

1 (IN) 4 (OUT) 3 (GND)

Connector M12x1

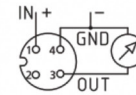

1 (IN) 3 (OUT) 4 (GND)

**Additional connections available upon request

DIMENSIONS (MM)**

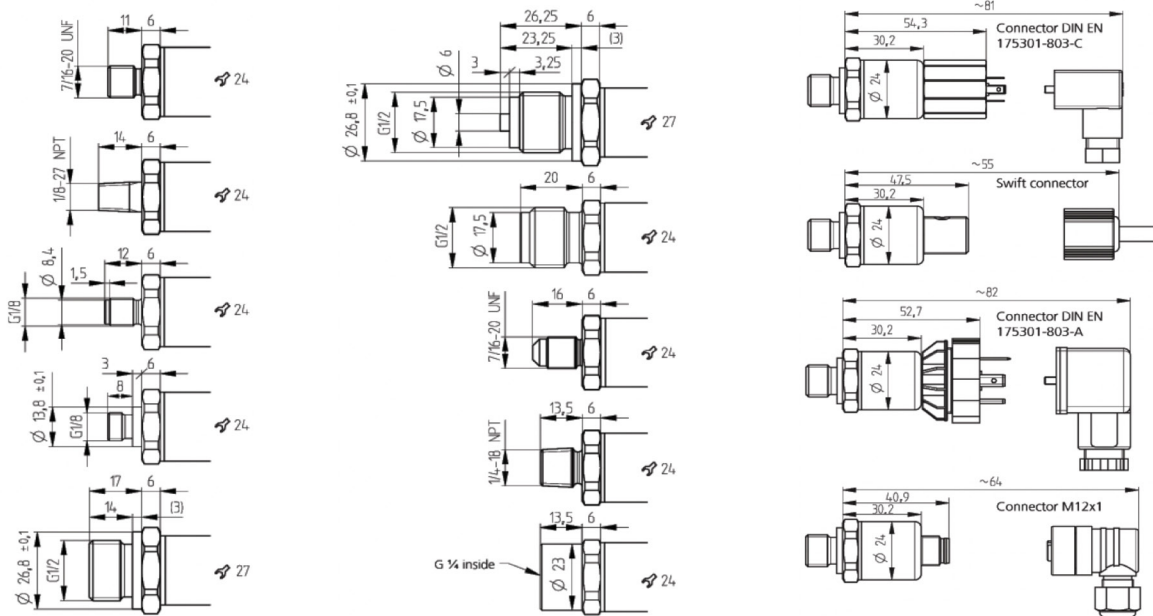

**Additional configurations available upon request

MOUNTING BRACKET

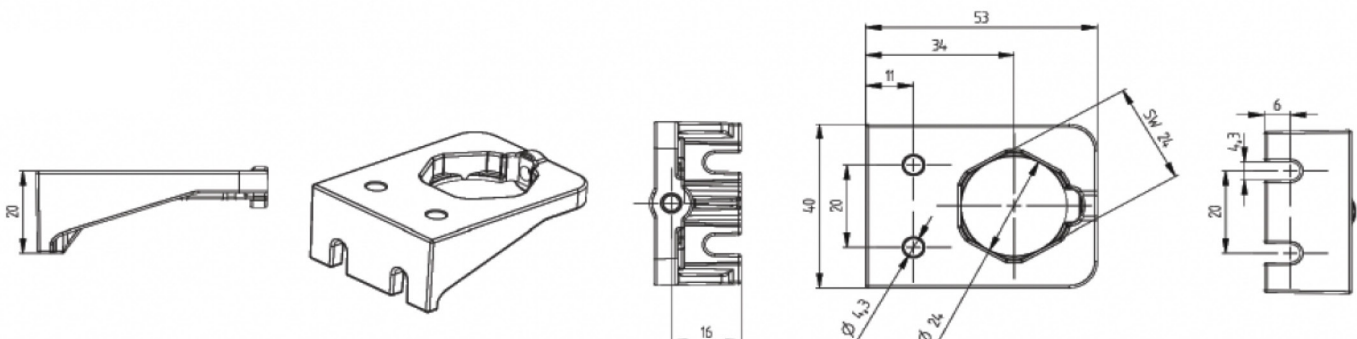

ORDERING INFORMATION PSI ONLY

**For ordering codes in Bar are available upon request

		1	2	3	4	5	6	7	8	9	10	11
Order code selection in psi		X	X	X	X	X	X	X	X	X	X	X
Pressure range (relative) ¹⁾	-30 ... 0" hg	9	B	0								
	0 ... 15 psi	9	B	1								
	0 ... 20 psi	9	B	2								
	0 ... 30 psi	9	B	4		0,4						
	0 ... 60 psi	9	B	5		0,4						
	0 ... 100 psi	9	B	7		0,4						
	0 ... 150 psi	9	C	0		0,4						
	0 ... 200 psi	9	C	1		0,4						
	0 ... 300 psi	9	C	2		0,4						1
	0 ... 500 psi	9	C	3		0,4						1
0 ... 750 psi	9	D	0		0,4						1	
Pressure range (absolute) ¹⁾	0 ... 15 psi 8 B 1	8	B	1								
	0 ... 20 psi 8 B 2	8	B	2								
	0 ... 30 psi 8 B 4	8	B	4								
	0 ... 60 psi 8 B 5	8	B	5								
	0 ... 100 psi 8 B 7	8	B	7								
	0 ... 150 psi 8 C 0	8	C	0								
	0 ... 200 psi 8 C 1	8	C	1								
Sealing material	FPM	Fluoro elastomer	(Ex -15 ... +120 °C)			0						
	EPDM	Ethylene propylene	(-30 ... +120 °C)		1							
	NBR	Butadiene Acrylonitrile	(Ex)		2							
	MVQ	Silicone polymer	(Ex -30 ... +120 °C)		3							
	FPM	Fluoro elastomer	(-30 ... +120 °C)		5							
Application	standard					0						
	for oxygen applications			0	1					1	1	
	with drinking water approval NSF 61			0	4					1	1	
Output / power supply	0 ... 5 V	7 ... 33 VDC					1					
	1 ... 6 V	8 ... 33 VDC					6					
	0 ... 10 V	12 ... 33 VDC					2					
		12 ... 33 VDC Enhanced EMC protection					C					
	ratiom. 10 ... 90%	12 ... 33 VDC / 24 VAC ±15% (not possible with M12x1, metri Pack, RAST, braids)					8					
		5 VDC ±10%					7					
		5 VDC ±10% Ex protection				0,4	9	1,3			1	
	4 ... 20 mA	7 ... 33 VDC					3					
7 ... 33 VDC Enhanced EMC protection (not possible with Braids)						A						
10 ... 30 VDC Ex protection					0,4	4	1,3			1		

			1	2	3	4	5	6	7	8	9	10	11	
			X	X	X	X	X	X	X	X	X	X	X	
Electrical connection	Connector ²⁾	DIN EN 175301-803-A							1					
		DIN EN 175301-803-C (industrial standard 9.4 mm)							2					
		M12x1 2w: IN=1 / OUT=3 3w: IN=1 / OUT=4 / GND=3								3				
		M12x1 2w: IN=1 / OUT=4 3w: IN=1 / OUT=3 / GND=4								M				
		M12x1 2w: IN=1 / OUT=2 3w: IN=1 / OUT=2 / GND=3								P				
		RAST 2.5				0,4	7			4				
		Metri Pack 150 P2S Series				0,4				5				
	Braids	80 ±10 mm								6				
		290 ±10 mm								7				
		480 ±10 mm								8				
		730 ±10 mm								9				
	Swift connector	without cable								0				
		with cable 1.5 m								L				
		with cable 2.0 m								N				
		with cable 3.0 m								Q				
		with cable 5.0 m								R				
Pressure connection ³⁾	Inside thread	7/16 -20 UNF sealing cone								K		1		
		½ -14 NPT D								D		1		
		G ¼ with O-Ring seal FPM								1		1		
	Outside thread	7/16 -20 UNF sealing cone									2		1	
		¼ -18 NPT									3		1	
		G ¼ sealed at back DIN 3852-E with profile seal ring in FPM									4		1	
		G ¼ sealed at back and manometer with profile seal ring in FPM									5	1	1	
		R ¼ acc. to EN 10226									7		1	
		G ½ sealed at back and manometer with profile seal ring in FPM				0,1					8		1	
		7/16 -20 UNF sealed at back SAE 4 with O-Ring seal FPM				0,1					G		1	
		¼ -27 NPT									A		1	
		G ¼ sealed at front									M		1	
		G ¼ sealed at back DIN 3852-E with Profile seal ring in FPM				0,1					H		1	
		G ¼ sealed at front									J			
		G ½ sealed at back DIN 3852-E with profile seal ring in FPM				0,1					C		1	
		M10x1 sealed at back DIN 3852-E with profile seal ring in FPM				0,1					F		1	
		M20x1.5 sealed at front and manometer (combi)									E		1	
		G ½ sealed at front									9			
Pressure orifice	without										1			
	with										2			
Material pressure connection	Stainless steel 1.4404 / AISI 316L											1		
	PVDF outside thread ³⁾	sealed at front G ¼, G ½	≤ 200 psi							1,9	1	2		
Pressure range variation (optional)	Indicate W and state range on order (e.g.: W0... + 16psi/OUT0...5V)												W	